

Material: Stainless Steel ASTM A351 CF8M 316SS

REVISION HISTORY			
REV	DESCRIPTION	DATE	DESIGNER
1	VALID - ORIGINAL DWG	5/5/14	JEREMY GARZA
2	Update weight	7/22/2014	Cristian Sanchez

Dimensions												
Pipe Diameter (in)	SDR	O.D.	T	I.D.	Bolt Count	Bolt Hole Size (H)	Bolt Hole Circle (BC)	R	Weight (lbs)	Pressure Class (PC)	FM APPROVED	
1"	7	4.250	0.560	1.380	4	0.630	3.130	0.125	1.1	335	N/A	
1 1/2"	7	5.000	0.690	1.970	4	0.630	3.880	0.200	1.7	335	N/A	
2"	7	6.000	0.750	2.460	4	0.750	4.750	0.270	2.5	335	FM(250psi)	
2"	11	6.000	0.400	2.460	4	0.750	4.750	0.270	1.7	200	N/A	
3"	7	7.500	0.940	3.600	4	0.750	6.000	0.330	4.4	335	FM(250psi)	
3"	13.5	7.500	0.400	3.600	4	0.750	6.000	0.330	2.5	160	N/A	
4"	7	9.000	0.940	4.600	8	0.750	7.500	0.390	5.8	335	FM(250psi)	
4"	13.5	9.000	0.500	4.600	8	0.750	7.500	0.390	3.6	160	N/A	
6"	7	11.000	1.000	6.750	8	0.880	9.500	0.440	8.2	335	FM(250psi)	
6"	13.5	11.000	0.600	6.750	8	0.880	9.500	0.440	5.6	160	N/A	
8"	7	13.500	1.120	8.750	8	0.880	11.750	0.440	12.5	335	FM(250psi)	
8"	13.5	13.500	0.700	8.750	8	0.880	11.750	0.440	8.2	160	N/A	
10"	7	16.000	1.340	10.920	12	1.000	14.250	0.430	19.6	335	FM(250psi)	
10"	13.5	16.000	0.900	10.920	12	1.000	14.250	0.420	11.1	160	N/A	
12"	7	19.000	1.770	12.920	12	1.000	17.000	0.500	34.8	335	FM(250psi)	
12"	11	19.000	1.250	12.920	12	1.000	17.000	0.420	24.0	200	FM(200psi)	
12"	13.5	19.000	1.050	12.920	12	1.000	17.000	0.420	19.6	160	N/A	
14"	7	21.000	1.890	14.180	12	1.130	18.750	0.430	47.7	335	FM(250psi)	
14"	11	21.000	1.610	14.180	12	1.130	18.750	0.430	37.7	200	N/A	
14"	17	21.000	1.130	14.180	12	1.130	18.750	0.410	24.4	125	N/A	
16"	7	23.500	1.970	16.190	16	1.130	21.250	0.400	57.9	335	FM(250psi)	
16"	11	23.500	1.890	16.190	16	1.130	21.250	0.430	52.4	200	N/A	
16"	13.5	23.500	1.440	16.190	16	1.130	21.250	0.500	52.0	160	N/A	
16"	17	23.500	1.250	16.190	16	1.130	21.250	0.410	29.9	125	N/A	
18"	7	25.000	2.170	18.200	16	1.250	22.750	0.430	63.2	335	FM(250psi)	
18"	11	25.000	1.560	18.200	16	1.250	22.750	0.500	52.1	200	FM(200psi)	
18"	21	25.000	1.340	18.200	16	1.250	22.750	0.400	33.0	100	N/A	
20"	7	27.500	2.320	20.250	20	1.250	25.000	0.430	87.4	335	FM(250psi)	
20"	11	27.500	2.150	20.250	20	1.250	25.000	0.430	73.8	200	N/A	
20"	21	27.500	1.470	20.250	20	1.250	25.000	0.375	39.0	100	N/A	
22"	7	29.500	2.480	22.250	20	1.380	27.250	0.430	102.9	335	FM(250psi)	
22"	11	29.500	2.250	22.250	20	1.380	27.250	0.430	86.6	200	N/A	
22"	21	29.500	1.540	22.250	20	1.380	27.250	0.375	50.0	100	N/A	

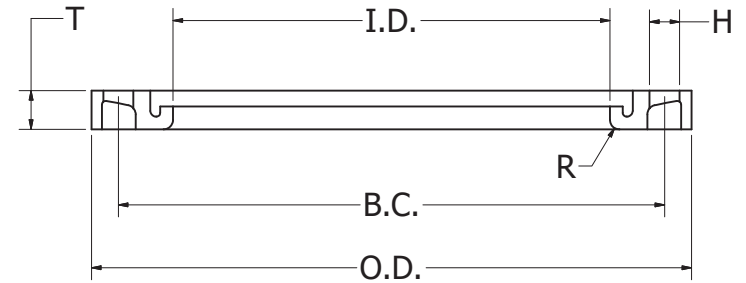
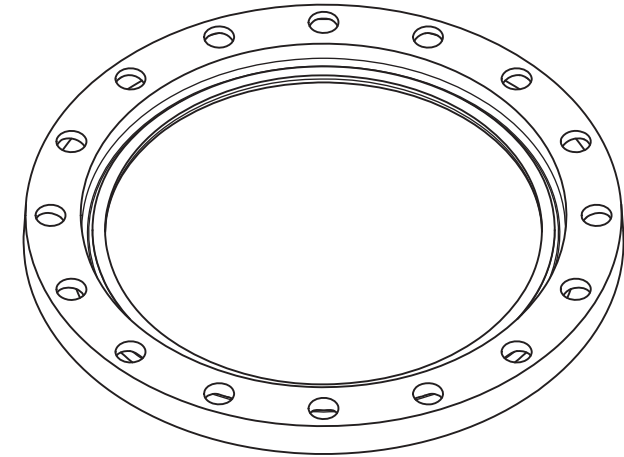

Ongoing engineering design efforts may affect the technical information listed in our publications.

Notes

Improved Piping Products' backing rings and blinds mate with AWWA C207, ANSI B16.5 and ANSI B16.47, as appropriate. Specifications not stated in these standards follow internal specifications.

**PP IMPROVED**  
PIPING PRODUCTS, INC.

TITLE  
SS-SDR Stainless Steel convoluted Flange / Backup Ring Submittal Sheet

UNLESS OTHERWISE NOTED, ALL DIMENSIONS IN INCHES

SIZE PART NO

SALES NO